



No Contact Switch

Cat XLP914WEWE

Instruction Manual

1 Specifications

Voltage	230-240V a.c.
Maximum Load	
Incandescent	1000W
240V halogen	1000W
12V halogen with electronic or wirewound transformer	500VA
Linear fluorescent	500VA
Compact fluorescent	500VA
Fan motor	100VA
Stand-by power	0.6W
Terminal capacity	2 x 1.5mm ² or 1 x 2.5mm ²
IP rating	IP41
Storage temperature	-10°C to +70°C
Operating temperature	-5°C to +50°C
Resistant to the following agents	Hexane, methylated spirits, soapy water, diluted ammonia, diluted pure bleach (10%), glass cleaning substance, pre-impregnated wipes, diluted hydrogen peroxide (35%)
Not resistant to the following agents	Acetone, tar remover, trichloroethylene

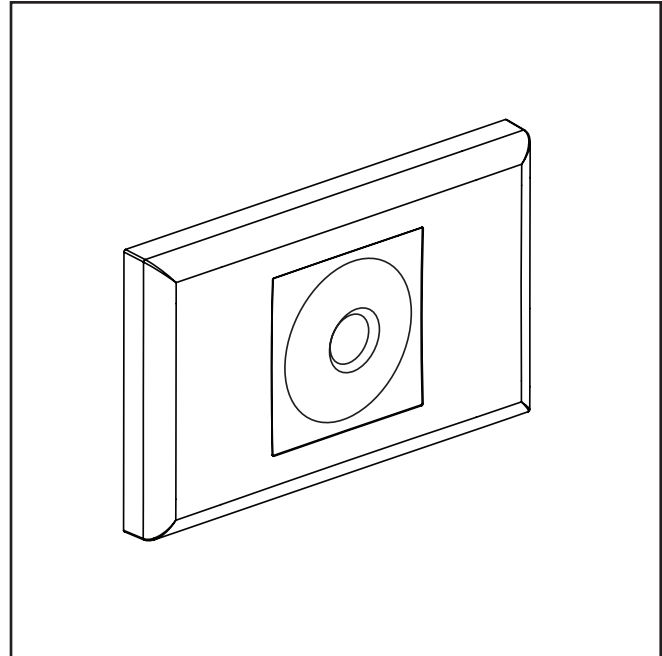

2 Operation

The switch turns on when a hand is moved within 50mm of the sensor. A subsequent hand movement will turn the switch off. The sensor glows when the switch is turned on.

Up to 5 switches can be wired in parallel to control the same load.

3 Mechanism Dimensions

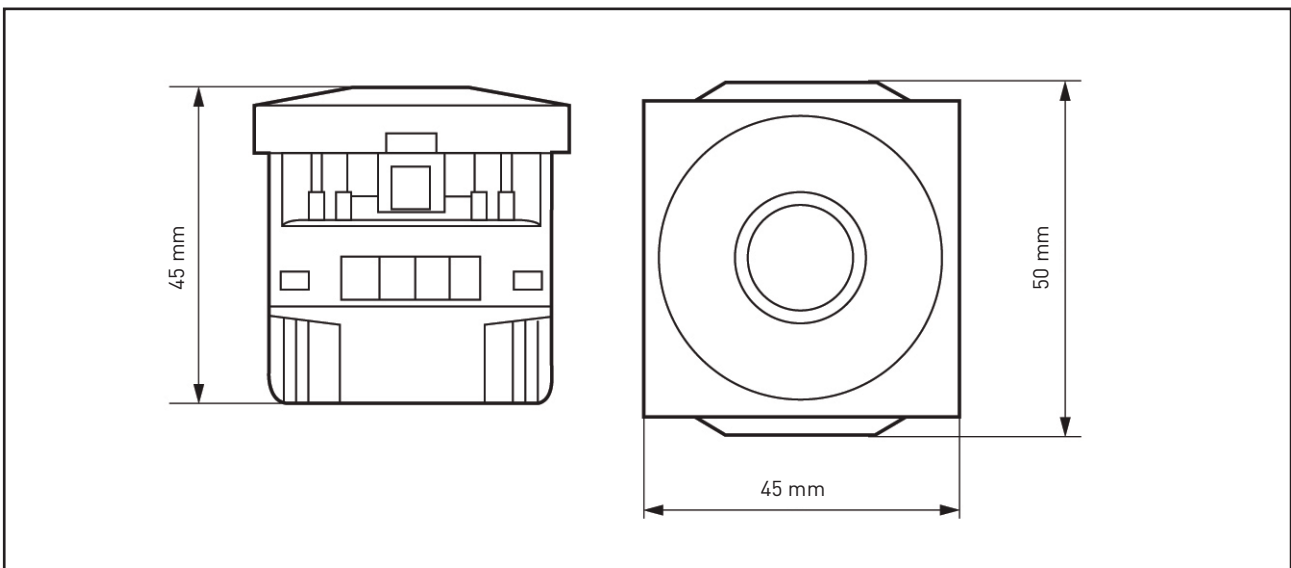

4 Wiring

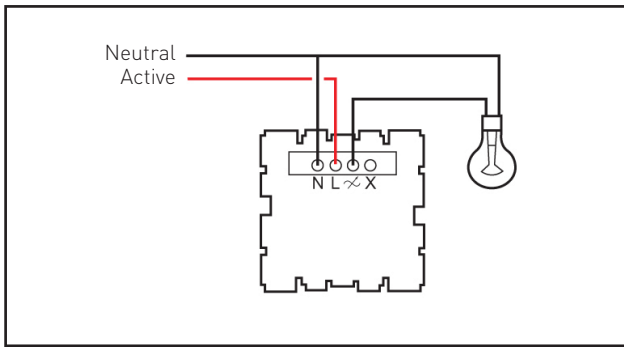

One-way wiring

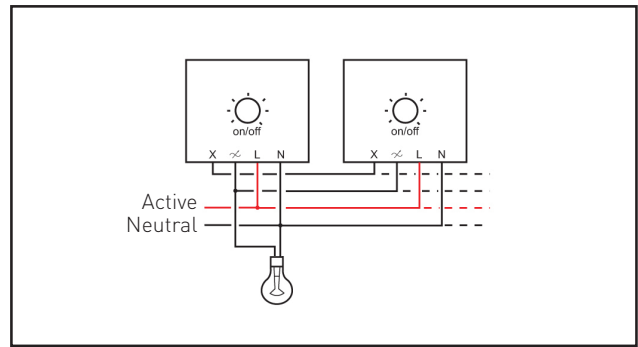

Multi-way wiring (maximum of 5 switches)

5 Warning

This product must only be connected to the mains supply by a qualified electrician.

Warranty

HPM Cat XLP914WEWE is warranted as here and after appears, against faulty material and/or workmanship for a period of one year from the day of purchase. The obligation of the manufacturer under this warranty is limited to servicing and replacing defective parts when the unit is returned to the authorised place of purchase. To obtain warranty repair, the purchase receipt should be returned with the product. This warranty becomes void on any unit which has been tampered with or damaged by accident, short circuited, loaded beyond rating or damaged otherwise by improper operation. The warranty is also conditional on the unit being installed by a licensed electrical contractor. All other warranties, whether expressed or implied, and whether arising by operation of law or otherwise are hereby excluded.

Customer Service

For all customer service and technical support please call Monday to Friday during business hours.

HPM Legrand Australia
1300 369 777
www.hpm.com.au

HPM Legrand - New Zealand
0800 476 009
www.hpm.co.nz

Legrand Australia Pty Ltd
ABN: 31 000 102 661

A Group Brand | 